

## 1100 LITRE DOMED LID CONTAINER: SECOND GENERATION, FIRST CLASS



**UNIQUE DESIGN  
EASY HANDLING  
IMPROVED SAFETY**

*Just "ASK"!*

**Mob: 0411 51 21 51**

### **Safety Handles**

- Easy grip handles on all sides
- Optimum manoeuvrability
- Compatible with identification and weighing systems



### **Safety Trunnion**

- Increased stability
- Increased safety when lifting



### **Safety Lid**

- High degree of safety with integrated child safety device
- Closes automatically after emptying



# 1100 Litre Domed Lid Container

## Material

- Polymer components:
  - Injection moulded from specially designed HDPE
  - Resistant to decay, frost, heat and chemicals
  - Special UV-stabilisers provide excellent ageing characteristics
- Corrosion resistant steel components
- Noise reduction:
  - Wheel assemblies with solid rubber tyres
- Long service life:
  - High quality materials
  - Excellent manufacturing processes
  - Withstands exposure to high mechanical stress levels
- Recycling:
  - All container parts are recyclable

## Design

- Easy to use lid, lockable, with adjustable spring support system
- High degree of safety - integrated child safety device prevents accidental closing of lid
- Versatile, with a comprehensive accessories range
- Easy grip handles on all sides
- Safe, easy handling, even with heavy loads
- Wide lifting trunnions for improved safety during lifting, even with awkward loads
- Various wheel assembly configurations for different applications
- Water drainage plug as standard†
- Compatible with identification and weighing systems
- Domed lid with unique opening mechanism reduces wind problems during emptying
- Easy to clean due to smooth surfaces and rounded internal surfaces
- Reinforced base, front and rear panels for greater stability

## Accessories

- For accessories and special design variations such as lid apertures, locks and towing brackets, please refer to the separate accessories sheet for 4-wheeled containers

## Quality

- Certified according to DIN EN 840 and RAL GZ 951/1
- Constant quality control through manufacturers laboratory as well as independent institutes

## Dimensions - Weights - Standards

- Nominal volume: 1100 litres
- Net weight: approx. 65 kg
- Max. load: 440 kg
- Permitted total weight: 510 kg

Measurements to be used as a guide only - variations will occur

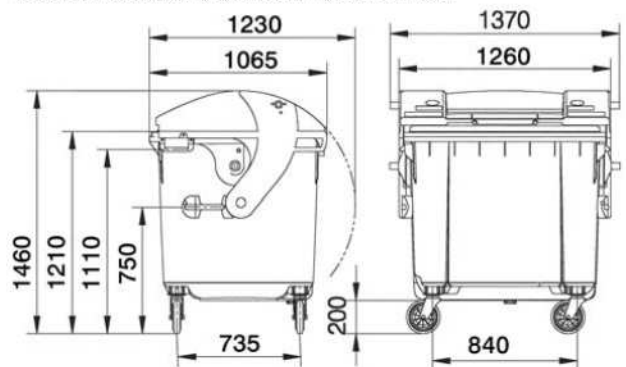

Note: Certification and Quality Marks depicted in this brochure are registered to SULO Umwelttechnik GmbH & Co. KG

## Colours

- Standard colours: green, blue, yellow
- Special colours are available on request\*
- All additives are cadmium free and environmentally friendly



## Imprints and markings

- Manufacturer, year of manufacture, material
- Nominal volume, max. permitted total weight
- EN 840, RAL markings
- Individual markings with imprints, hot-foil printing or adhesive labels available on request\*

# SULO®

available from...

**ASK** Equipment Sales  
(QLD)

PO Box 7224, Redland Bay 4165, QUEENSLAND AUSTRALIA

Phone: +61 (0)7 3807 6113

Email: [info@askequipmentsalesqld.com.au](mailto:info@askequipmentsalesqld.com.au)

Fax: +61 (0)7 3807 8113

Web: [www.askequipmentsalesqld.com.au](http://www.askequipmentsalesqld.com.au)