

80 LITRE KOMPAKT CONTAINER: IDEAL FOR 'SMALL WASTE' NEEDS



EASY HANDLING
VERSATILE
STABLE DESIGN

Just "ASK"!

Mob: 0411 51 21 51

Designed for local market

- Manufactured in accordance with AS4123
- Compact dimensions are perfect for limited space locations
- High degree of mobility
- Resistant to UV degradation



Multiple applications

- Waste container for multi-unit dwellings and homes
- Materials handling
- Medical practice treatment rooms
- Kitchen waste containers



Improved design features

- Internal concave floor assists emptying
- Thicker handle for improved control
- Flexibility in bin and lid markings



80 LITRE CONTAINER

Material

- **Polymer components:**
 - Injection moulded from specially designed HDPE
 - Resistant to decay, frost, heat and chemicals
 - Special UV-stabilisation provides excellent ageing characteristics
- **Corrosion resistant steel axle**
- **Noise reduction:**
 - Quiet-running solid rubber tyres
 - Tight-fitting axle
- **Long service life:**
 - High quality materials
 - Most advanced manufacturing processes
 - Withstands exposure to high mechanical stress levels
- **Recycling:**
 - All container parts are recyclable

Advantages

- Easy to manoeuvre
- Versatile, with a comprehensive accessories range
- Complies with EN840 and AS4123 quality requirements
- Particularly stable due to external position of wheels
- Safe and easy to handle
- Suitable for all DIN lifting equipment
- Double angle rail for greater safety when emptying
- Compatible with identification and weighing systems
- Special ribs prevent containers from becoming jammed when stacked

Imprints and markings

- Manufacturer, year of manufacture, material
- Nominal volume, max permitted total weight
- EN 840 & AS4123 markings
- Individual markings with imprints, hot-foil printing or adhesive labels*
- Customer specific serial numbers if required*

Accessories

- For accessories and special design variations such as lid apertures and locks please refer to the separate accessories sheet for 2-wheeled containers

Quality

- Certified according to EN840
- Manufactured in accordance with AS4123

Dimensions - Weights - Standards

- Nominal volume: 80 litres
- Net weight: approx 8.5 kg
- Max load: 32 kg
- Permitted total weight: 40 kg

- A 840 mm ■ D 510 mm ■ G 480 mm
- B 795 mm ■ E 450 mm
- C 480 mm ■ F 300 mm

Measurements to be used as a guide only – variations will occur

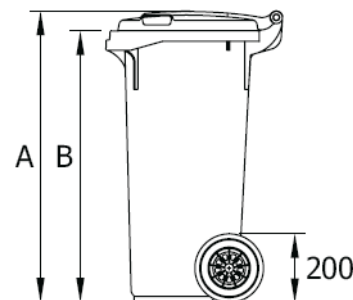
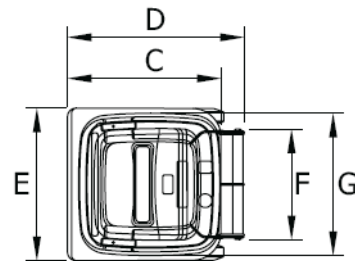

Colours

- Standard colours: nature green, dark green, grey
- Special colours are available on request* – common colours include blue, yellow, red, brown



SULO®

available from...

DIN



PO Box 7224, Redland Bay 4165, QUEENSLAND AUSTRALIA

Phone: +61 (0)7 3807 6113

Email: info@askequipmentsalesqld.com.au

Fax: +61 (0)7 3807 8113

Web: www.askequipmentsalesqld.com.au