

240 LITRE CONTAINER: STILL GOING STRONGLY



EASY HANDLING
VERSATILE
STABLE DESIGN

Adheres to all standards

- Manufactured in accordance with AS4123
- Built to International standards for MGBs (EN840)
- Resistant to UV degradation
- Colour range to meet 'waste stream' standards



Multiple applications

- Household refuse
- Commercial waste
- Recyclable materials
- Household organics



Improved design features

- Internal concave floor assists emptying
- Thicker handle for improved control
- Flexibility in bin and lid markings



Just "ASK"!

Mob: 0411 51 21 51

240 LITRE CONTAINER

Material

- **Polymer components:**
 - Injection moulded from specially designed HDPE
 - Resistant to decay, frost, heat and chemicals
 - Special UV-stabilisation provides excellent ageing characteristics
- **Corrosion resistant steel axle**
- **Noise reduction:**
 - Quiet-running solid rubber tyres
 - Tight-fitting axle
- **Long service life:**
 - High quality materials
 - Most advanced manufacturing processes
 - Withstands exposure to high mechanical stress levels
- **Recycling:**
 - All container parts are recyclable

Advantages

- Easy to manoeuvre
- Versatile, with a comprehensive accessories range
- Complies with EN840 and AS4123 quality requirements
- Particularly stable due to external position of wheels
- Safe and easy to handle
- Suitable for all DIN lifting equipment
- Double angle rail for greater safety when emptying
- Compatible with identification and weighing systems
- Special ribs prevent containers from becoming jammed when stacked

Imprints and markings

- Manufacturer, year of manufacture, material
- Nominal volume, max permitted total weight
- EN 840 & AS4123 markings
- Individual markings with imprints, hot-foil printing or adhesive labels*
- Customer specific serial numbers if required*

Accessories

- For accessories and special design variations such as lid apertures and locks please refer to the separate accessories sheet for 2-wheeled containers

Quality

- Certified according to EN840
- Manufactured in accordance with AS4123

Dimensions - Weights - Standards

■ Nominal volume:	240 litres				
■ Net weight:	approx 13 kg				
■ Max load:	96 kg				
■ Permitted total weight:	110 kg				
■ A	1060 mm	■ D	730 mm	■ G	550 mm
■ B	990 mm	■ E	585 mm		
■ C	660 mm	■ F	400 mm		

Measurements to be used as a guide only - variations will occur

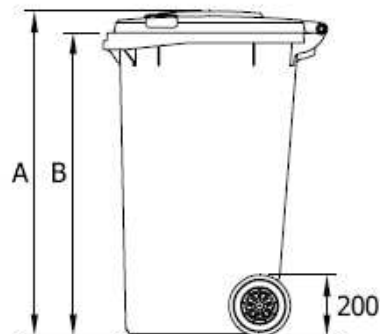
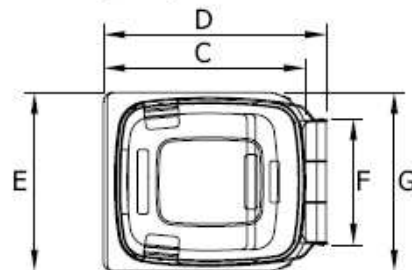

Colours

- Standard colours: nature green, dark green, grey
- Special colours are available on request* - common colours include blue, yellow, red, brown, orange, purple



SULO®

available from...



PO Box 7224, Redland Bay 4165, QUEENSLAND AUSTRALIA

Phone: +61 (0)7 3807 6113

Email: info@askequipmentsalesqld.com.au

Fax: +61 (0)7 3807 8113

Web: www.askequipmentsalesqld.com.au